



Eco-Friendly High Efficiency Turbo Blowers and Compressors

Turbo Blower NX Series Turbo Compressor NC Series

Masterpiece beyond compare

Customer satisfaction is our number one priority at Neuros which is the secret behind every blower that we make. NX and NC series are the embodiment of highest efficiency and quality.



THE HIGHEST PERFORMANCE

With many years of experience in the research and development of gas turbine engines, used in aircraft, and production know-how of turbo machineries, Neuros' Turbo Blowers and Turbo Compressors provide the world best performance reaching up to 75% of total efficiency.



EXCELLENT RELIABILITY

Its Award Winning High Speed Turbo Blowers are considered the industry reference for high quality thanks to the use of proven state-of-the-art air bearing, PMSM and blower aeration control system technologies.



ECONOMICAL LIFE CYCLE COST

NX and NC series provide the end users with significant reduction in operating costs through energy savings of up to 40% (according to third party studies), low installation and maintenance costs – only air filters need periodical cleaning or replacing.



CUSTOMER ORIENTED TECHNOLOGY

User-friendly PLC for easy control, monitoring and diagnostics. Eco-friendly technology with low noise and vibration and no lubricating oil required.

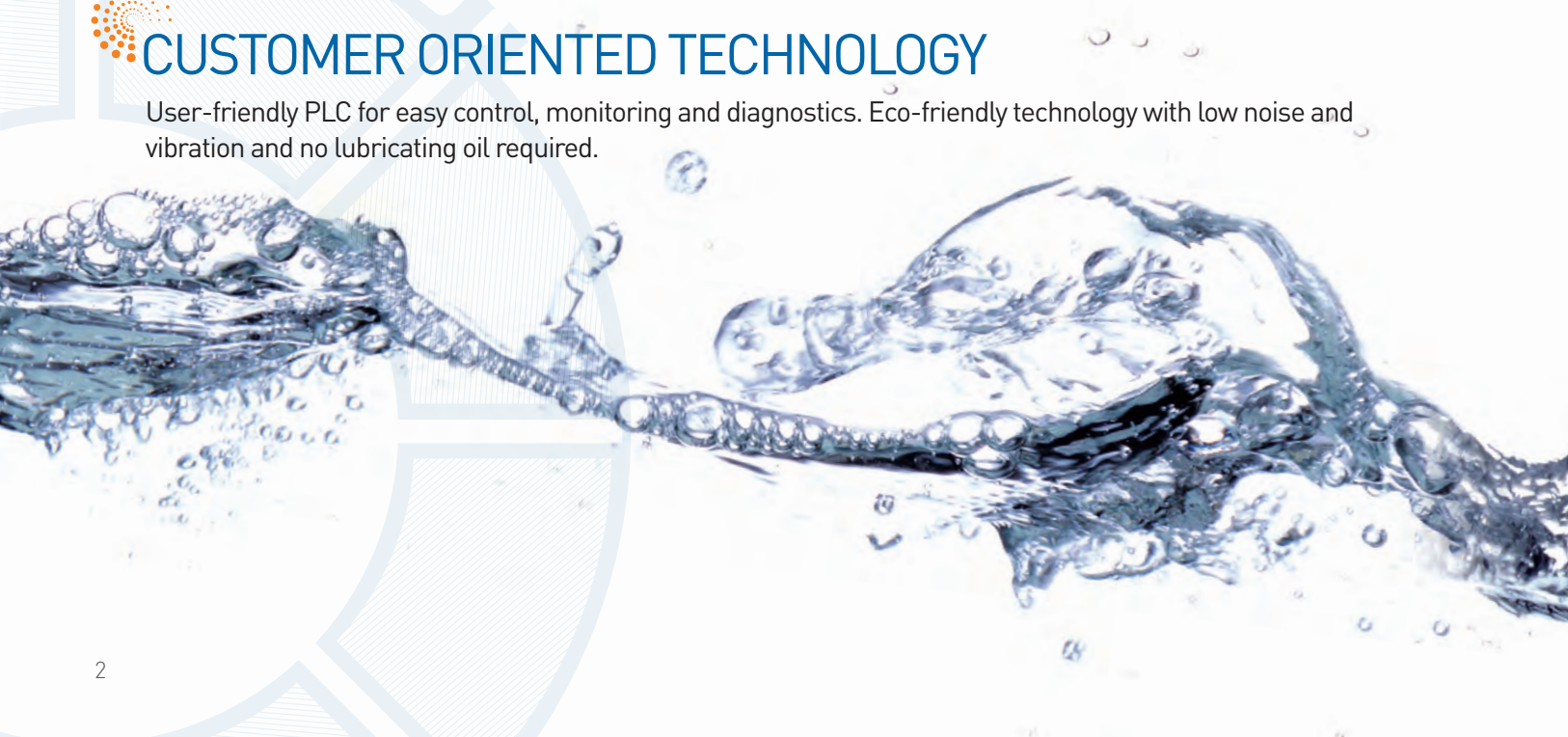

Born from aerospace technology

Neuros' Turbo Blower and Compressor technology was founded and utilized in the aerospace and defense industry, making the technology tested and reliable. Consequently, Neuros acquired a premium brand reputation by providing sustainable and energy efficient solutions to its customers.

Neuros will continue providing value-added energy efficient solutions through the continuous improvement, development and innovation of industrial turbo machineries as well as the commercialization of the next generation turbo charger and the environmental control system in the field of automation and aviation industry.



THE HIGHEST PERFORMANCE

The ultimate turbo machinery integrating the state-of-the-art aerospace high performance technologies.

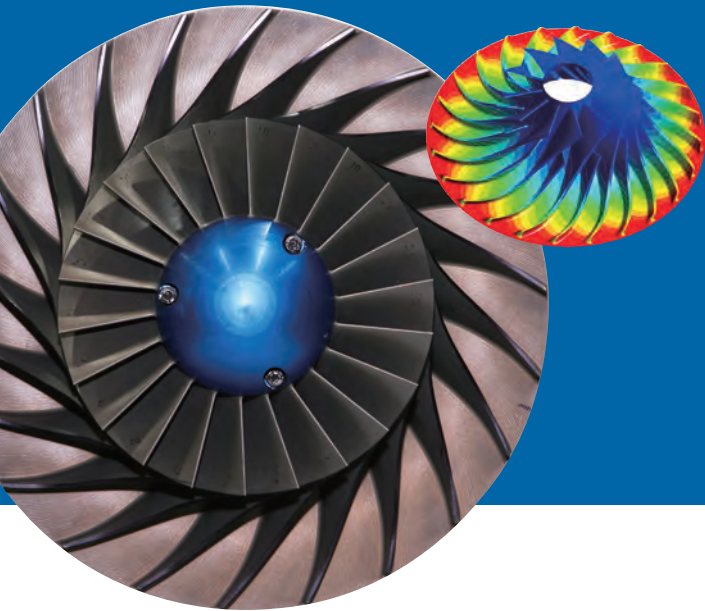

High Efficiency Impeller with Aerodynamic Optimization Design

- The design of the impeller and diffuser plays a key role in maximizing the efficiency of the turbo machinery.
- Impeller has higher integrity and higher fatigue life, as well as a larger diameter and precise impeller shape combined with optimal specific speed resulting in higher efficiency.
- Impeller's structural integrity is verified by a Spin Test at a rotational speed of 120%.
- Most suitable material, forged Aluminum Alloy, is used for the high-speed turbo machinery to manufacture the impeller; which is machined with a 5-axis CNC machine to minimize tip clearance.
- A hard anodizing coating on the impeller and casing improves corrosion resistance and durability.

High Speed PMSM

- Self-developed Permanent Magnet Synchronous Motor(PMSM) has a high efficiency and power factor of more than 95%.
- Permits continuous operation with low current loss and offers excellent speed control.
- There is negligible mechanical loss during operation thanks to the rotor of motor and impeller being directly coupled.

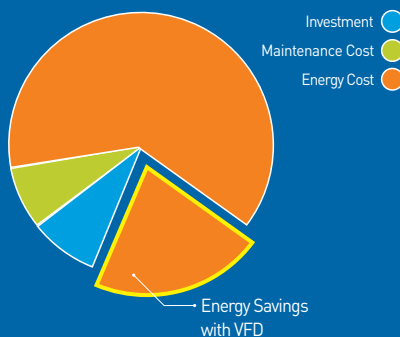

High Efficiency VFD

- The Variable Frequency Drive(VFD) conserves energy by controlling the rotational speed of the PMSM in order to adjust the discharge pressure and flow rate to meet customer needs.
- Inverter start of below 100% current at the time of initial start
- Rapid load response

EXCELLENT RELIABILITY

Proven air bearing and patented cooling system ensures continued trouble-free operation.

Aerospace Air Bearing Technology

- Non-contact air bearing that utilizes the dynamic pressure of air fluid. It is composed of two parts: a corrugated bump foil and high temperature alloy inner foil. As the rotor speeds up, a thin film of air creates a cushion between the shaft and the bearing surface.
- 100% Oil-Free Compressed Air – no lubricating oil or associated maintenance required.
- Reliable and proven technologies used in Aircraft Environmental Control Systems and Air Cycle Machines.
(Neuros air bearing used in a small-size turbo compressor installed in a fuel cell vehicle passed a 1,000,000 start/stop test.)
- Patent No. 10-0964883 ; Patent No. 10-1068542

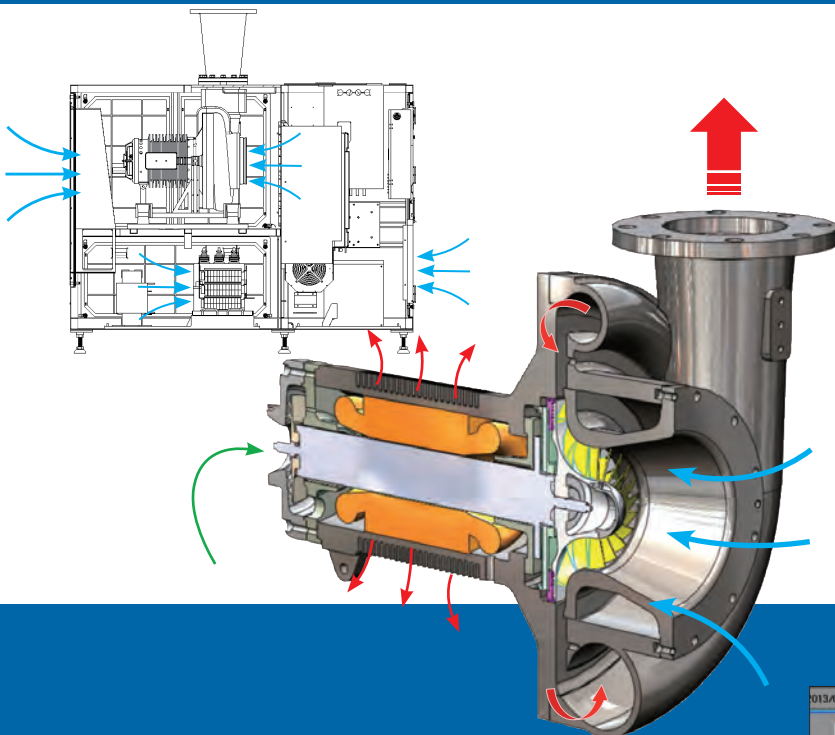
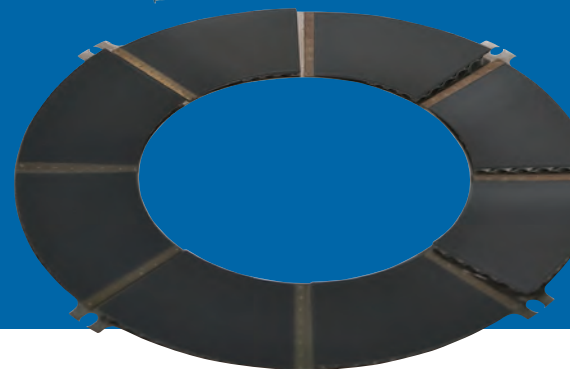
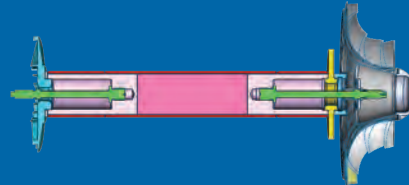

Patented Cooling System

- The blower motor, VFD and other electrical components are cooled off using blower inlet air.
- No heat emission from the blower to the surroundings
- Cooling System Patent No. 10-0572849

Surge Protection Logic

- Built-in Protection Logic in the blower to prevent surge during its operation by controlling its speed or blowing off air automatically.



ECONOMICAL LIFE CYCLE COST

Low LCC thanks to the blower's energy savings and low maintenance costs.

• Neuros Turbo Blower

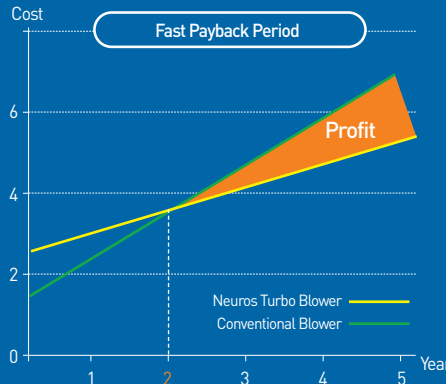
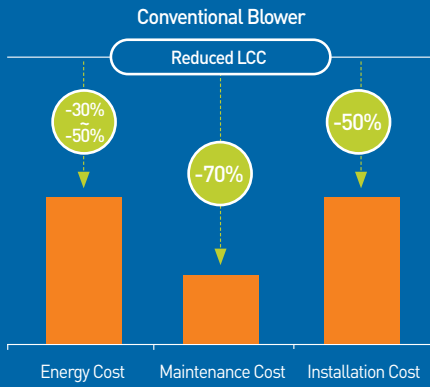

Return on Investment

- NX and NC series can maximize the profitability of end users through significant reduction of LCC.
- Neuros' Turbo Compressors save customers 50 to 70% of energy in applications that require a more flexible operation with air pressure of 120 - 250 kPa by replacing conventional compressors which produce 700 - 1,000 kPa.

Low Maintenance Cost

- Regular maintenance involves only cleaning or replacing air filters.
- No expenditures on the replacement of oil, oil filters and water cooling systems.
- Reduced labor costs



	New Filtration System		Remarks	Applying
	Pre Filter	Main Filter		
Filtration Efficiency	80% @ 100 μm	99% @ 2 μm	ASHRAE 52.2-1999	
Type	Coarse	Fine		
Material	Non-woven Fabric	Synthetic Fiber		
Stage	2 Stages (Pre Filter + Main Filter)			
Maintenance	<ul style="list-style-type: none"> • Air Wash once a month • Replacement every 3 months 	Replacement every 3-6 months	<ul style="list-style-type: none"> • Warning & Fault Alarms • Depending on Circumstances 	

Improved Filter System

- NX and NC series use a Two-Stage filtration system to protect the mechanical and electrical components and increase their efficiency.
- An alarm will alert the operator when the differential pressure goes above a preset point indicating that the filter needs to be replaced.

CUSTOMER ORIENTED TECHNOLOGY

Easy to use control system and eco-friendly technology.

Control System to Meet Various Customer Demands

- Programmable Logic Controller is the central control point of the blower. It allows the end users to run the blower in automated mode at constant speed, pressure, flow or dissolved oxygen control mode.
- It is equipped with an easy to use touch screen which allows for easy control, monitoring and diagnostics to view all blower parameters and conditions.
- The blowers and compressors can be controlled and monitored remotely using a Master Control Panel through communication protocols such as Ethernet, Modbus, Profibus, and Hard Wiring.
- Various languages are available including English, Chinese, Japanese, Korean, Turkish and Russian.



Eco-Friendly & User-Friendly Design

- Thanks to the patented non-contact air bearing and enclosure, the blower has very low vibration of less than 1mm/s without the special foundations and noise levels below 85 dB(A).
- Patent No. 10-0572850
- No environmental pollution thanks to the 100% Oil-Free System
- CO₂ emission reduction thanks to the energy savings
- Construction, electricity and plumbing costs are reduced thanks to the smaller footprint.
- Plug & Play operation with “all-in-one package”

Optional Items

- Master Control Panel (MCP) can be used to control up to 12 blowers giving the operator one point of control and monitoring, and each machine can be controlled through the remote communication with SCADA.
- Harmonic Filter can be installed inside or outside the enclosure of NX and NC series which provides an additional level of protection from harmonic distortion, removing harmonics generated during operation below the levels of THD_V 5%, THD_I 8%.

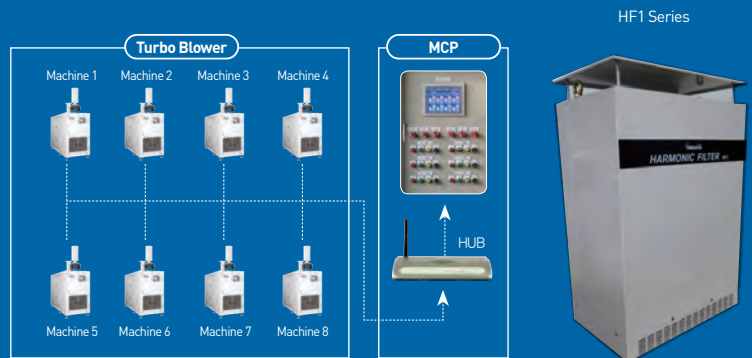



Eco-Friendly High Efficiency Turbo Blowers and Compressors

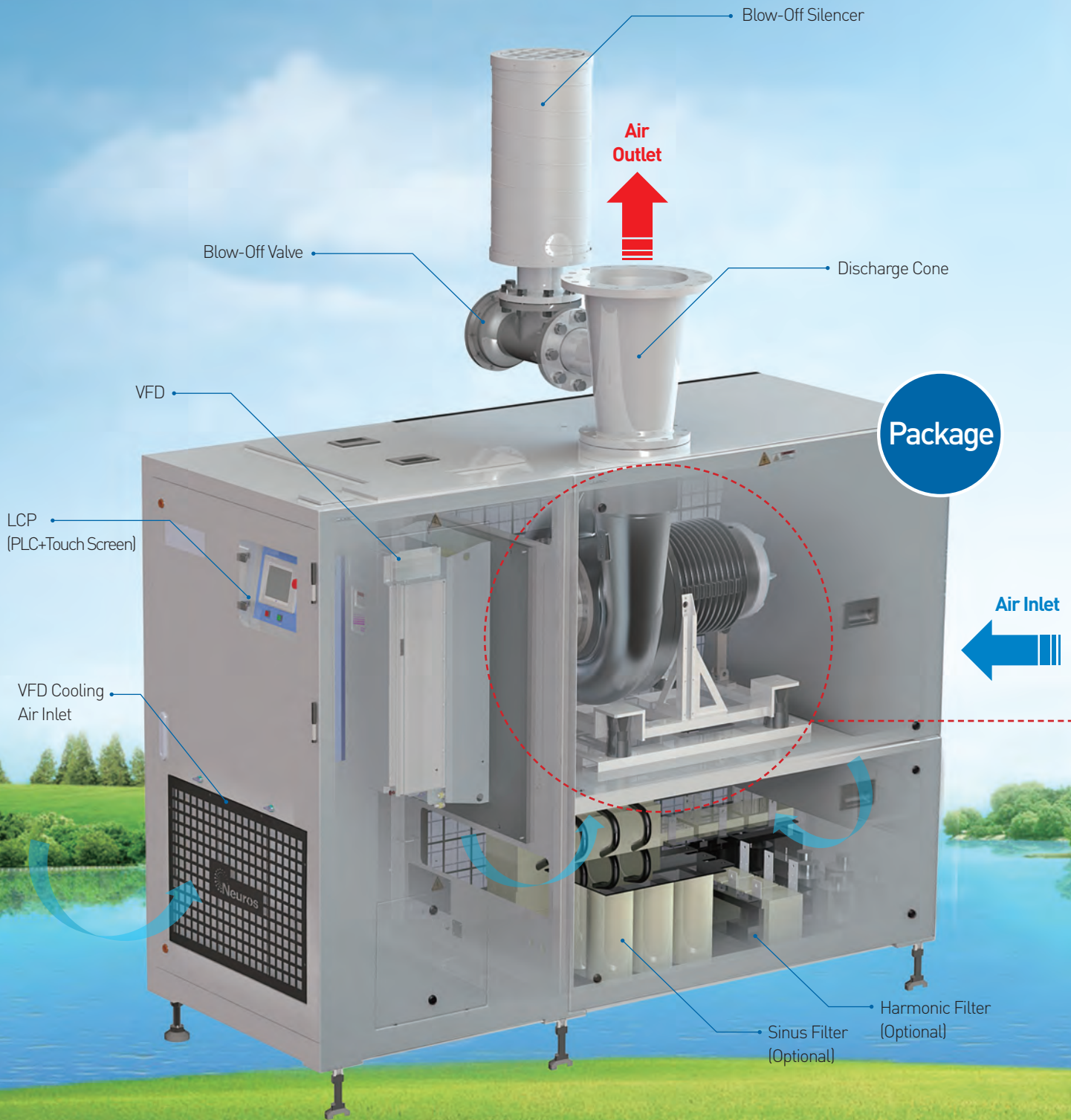

Are a Smart Choice for Mankind and the Environment

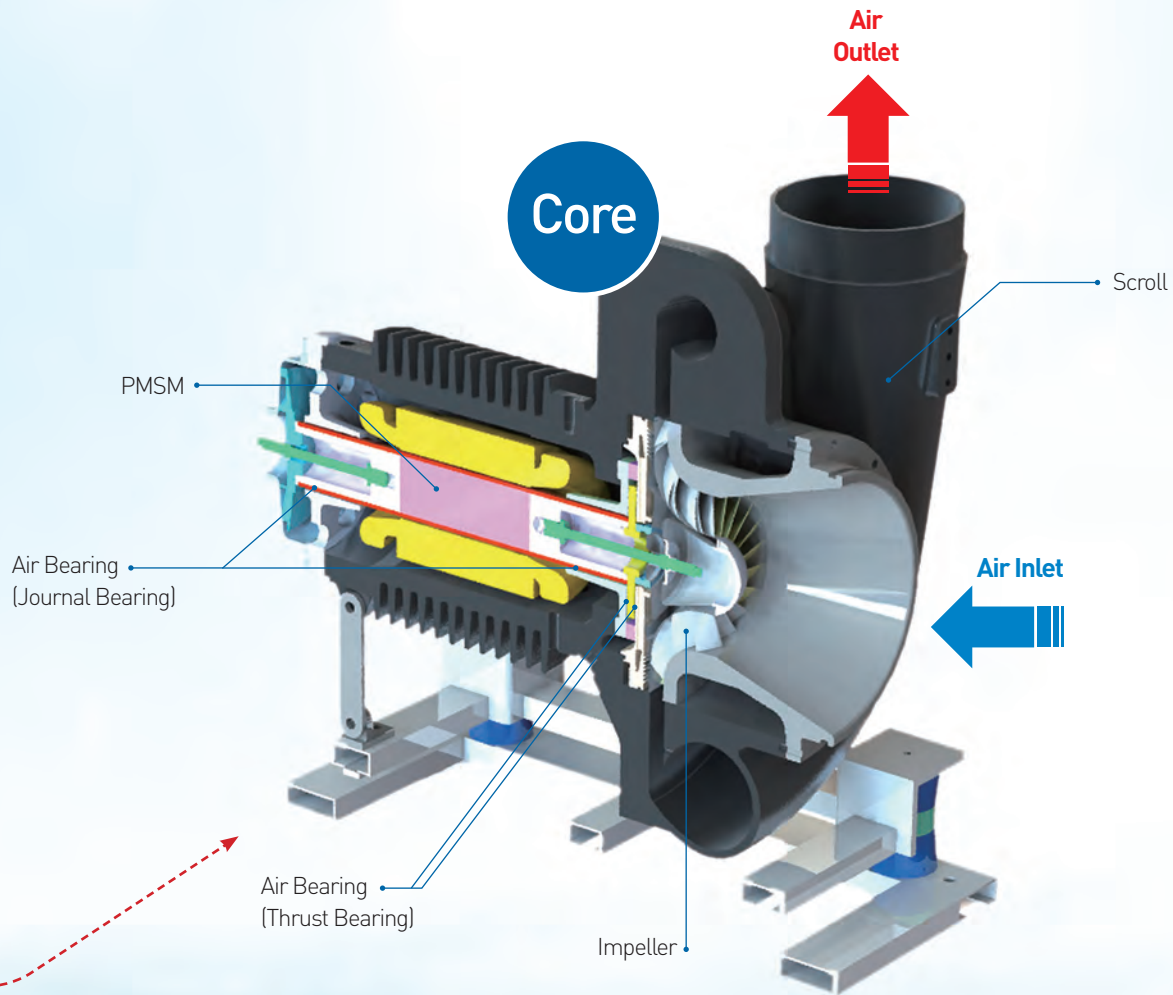

Turbo Blower NX Series

- Suction Flow Rate: 9-532 m³/min
- Discharge Pressure : 0.3-1.0 kgf/cm²G
- Turndown : 45-100%
- Noise Level : Below 85dB(A)
- 100% Oil-Free System

Turbo Compressor NC Series

- Suction Flow Rate: 12-230 m³/min
- Discharge Pressure : 1.1-2.0 kgf/cm²G
- Turndown: 70-100%
- Noise level: Below 85dB(A)
- 100% Oil-Free System

Product Specifications

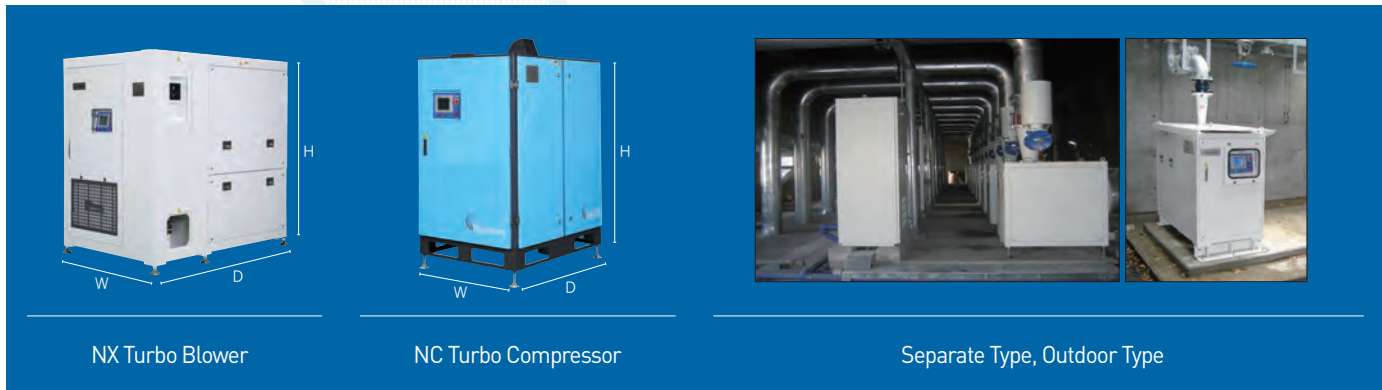

NX Turbo Blower

NC Turbo Compressor

Separate Type, Outdoor Type

Specifications

Model	Specifications			Dimensions and Weights(standard)			
	Cooling	Suction Flow (m ³ /min)	Motor Power (kW)	W (mm)	D (mm)	H (mm)	Weight (kg)
NX30	Air	9 ~ 23	22	770	1070	940	330
NX50	Air	19 ~ 45	37	770	1550	1350	580
NX75	Air	28 ~ 62	56	770	1550	1350	620
NX100	Air	42 ~ 98	74	770	1550	1350	700
NX150	Air	63 ~ 129	111	770	1750	1350	800
NX200	Air	85 ~ 167	149	1000	2300	1650	1190
	Water	85 ~ 167	149	1000	2100	1650	1090
NX250	Air	98 ~ 169	179	1400	2100	1810	1500
	Water	98 ~ 169	179	1400	2100	2020	1600
NX300	Air	131 ~ 257	223	1400	2100	1810	1500
	Water	131 ~ 257	223	1400	2100	2020	1750
NX350	Air	144 ~ 266	246	1400	2100	1810	1590
	Water	144 ~ 266	246	1400	2100	2020	1780
NX400	Air	170 ~ 334	298	1680	2240	1900	2140
	Water	170 ~ 334	298	1680	2240	1900	2150
NX500	Air	196 ~ 337	358	1880	3000	2150	2980
	Water	196 ~ 337	358	1880	3000	2150	2750
NX600	Air	262 ~ 514	447	1880	3000	2150	2950
	Water	262 ~ 514	447	1880	3000	2150	3020
NX700	Air	288 ~ 532	492	1880	3000	2150	3130
	Water	288 ~ 532	492	1880	3000	2150	3080
NC50	Air	12 ~ 14	37	1010	1300	1620	720
NC100	Water	26 ~ 33	74	970	1750	1560	980
NC300	Water	82 ~ 115	223	1400	2100	2020	1920
NC600	Water	164 ~ 230	447	1880	3000	2150	3330

※ Discharge Pressure: NX series(0.3 ~ 1.0 kgf/cm² G), NC series(1.1 ~ 2.0 kgf/cm² G)

※ Reference Conditions: 1.033 kgf/cm² A, 20°C, 65% RH

※ Tolerance: Air Flow ±4%, Power ±5%

※ Compliant with ISO5389, ASME PTC 10

※ The specification of the product may be changed for improvement of performance without notice.

Reference Sites

1. Water and Waste Water Treatment Plant



Daejeon WWTP (NX200), Korea



Hoeya WWTP (NX150), Korea



Suji WWTP (NX300), Korea



Sudokwon Landfill Site (NX150), Korea



Hollister (NX100/NX150), USA



Rupert (NX300), USA



He Dong (NX300), China



Chang Sha (NX300), China



Podolsk (NX300), Russia



Malatya 2 OSB (NX300), Turkey



Kyowa (NX300), Japan



Abu Dhabi (NX300), UAE

2. Industry



Honam Petrochemical (NX50), Korea



LG Chemical Ulsan (NX150), Korea



POSCO 4CGL (NX150), Korea



Nisshin Steel (NX100), Japan

3. Dual Core



American Bottoms (NX600), USA



Cincinnati (NX500), USA



Tuzla Deri OSB 2 (NC600), Turkey



Yuhan-Kimberly (NC500), Korea

Service Network in India

USHA NEUROS TURBO LLP. operates a network of key locations in India and promises to do its best to provide prompt service.

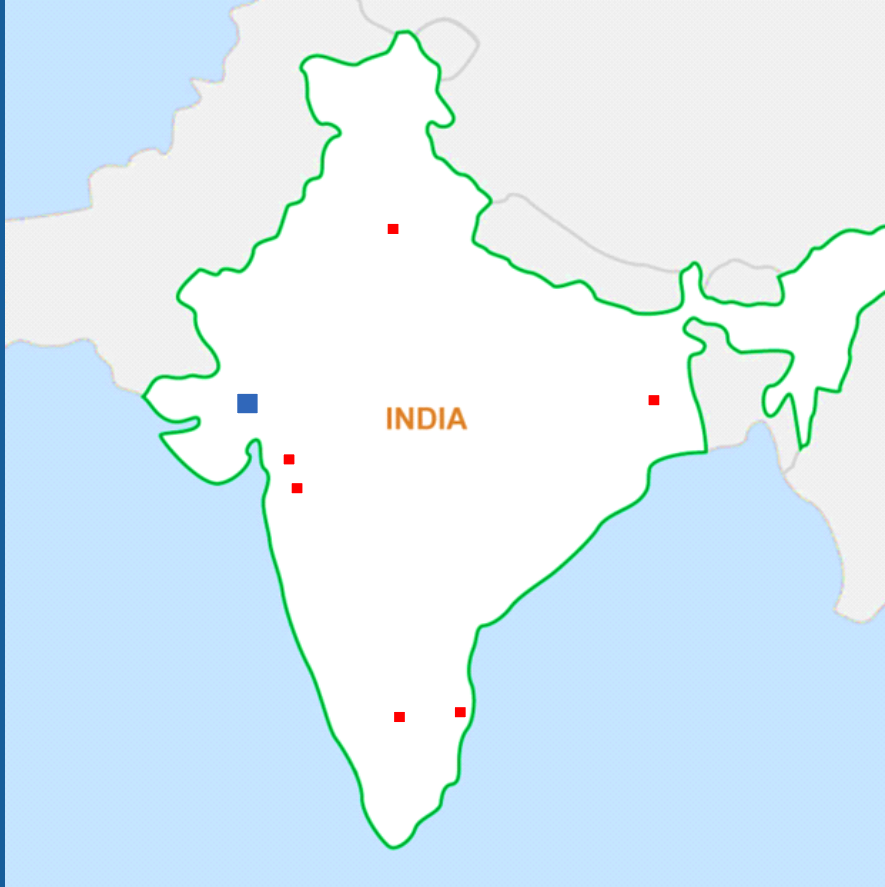

MUMBAI

1, Salooni Apartment, 56th Road,
TPS III, Borivali (W), Mumbai - 400 092.
Tel. : 022-28990680, 6
E-mail : mumbai@ushacompressors.com
ushacompressors@yahoo.com

KOLKATA

Flat No. 5, 5th Floor, Block 4,
Shawbhum Residency, 12-Motijhil Avenue,
Kolkata - 700 074
Mobile : +91 93398 72539
E-mail : kolkata@ushacompressors.com
kolkata.ucpl@gmail.com

BENGALURU

G-2, Marutham Green View,
5th 'C' Cross M. R. Gardens V. Nagenahalli,
R. T. Nagar, Bengaluru - 560 032.
Mobile : +91 80953 45139
E-mail : south.ucpl@gmail.com
sales@ushacompressors.com

BARODA Cell. : +91 83474 33433

SURAT Cell. : +91 98240 74858

VAPI Cell. : +91 98243 96007

+91 93223 35315

DELHI Cell. : +91 98240 31618

+91 98243 96007

CHENNAI Cell. : +91 80953 45139

+91 81550 08185

HEAD OFFICE & FACTORY

Survey No. 70, PO. Bavla - Bagodara
Highway, Ta Bavla, Ahmedabad - 382 220,
Gujarat, India
E-mail : sales@ushaneuros.com
customercare@ushaneuros.com